

PRI MIUS

SERIES

WATERJET CUTTING
SYSTEMS



 **INTERMAC**

MACHINING OPERATIONS WITH NO LIMITS

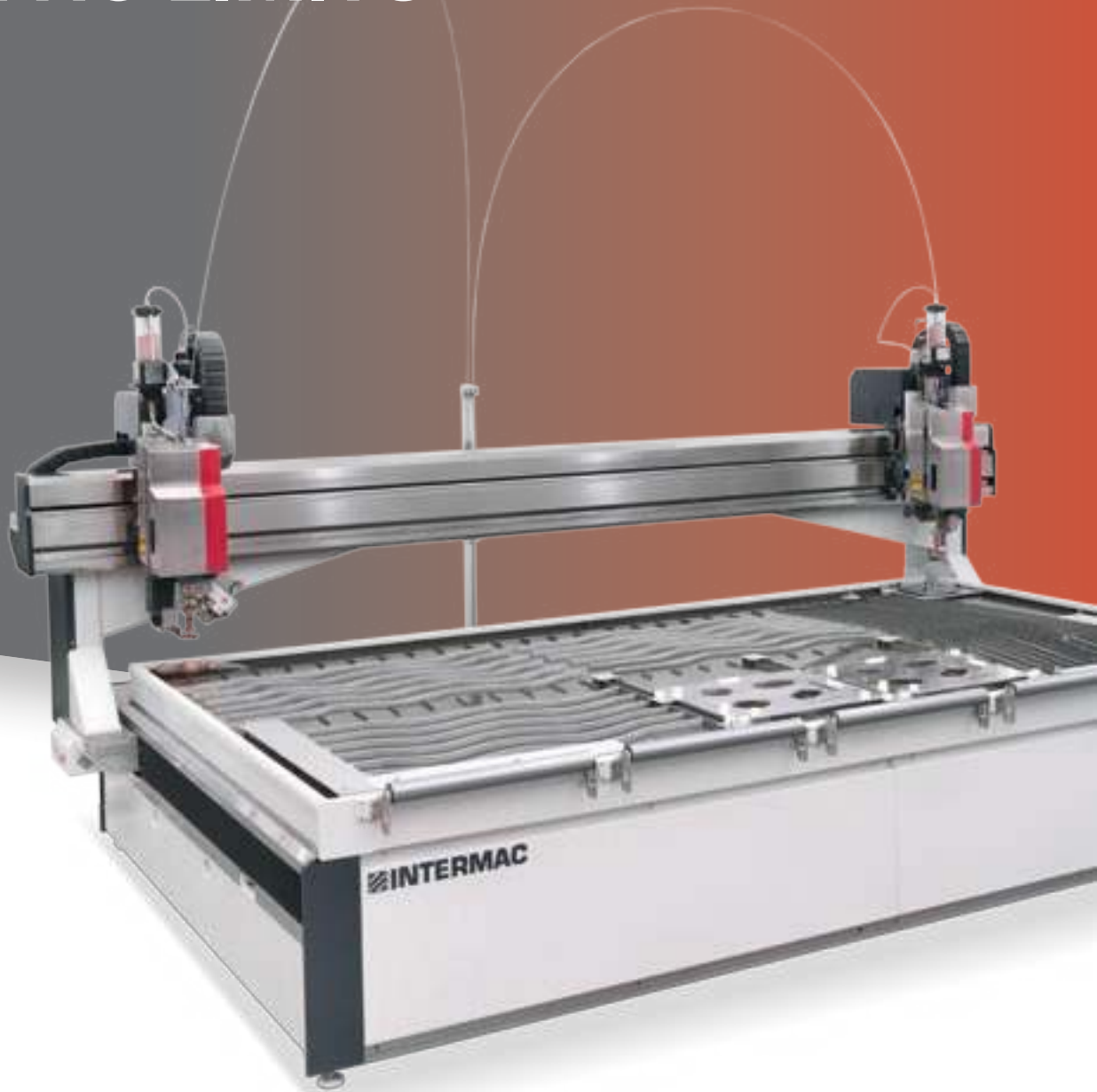

THE MARKET DEMANDS

a change in manufacturing processes, enabling companies to accept the largest possible number of orders. This is coupled with the need to maintain high quality standards while offering product customisation with quick and defined delivery times, as well as satisfying the requirements of even the most highly-automated industries.

INTERMAC RESPONDS

with technological solutions which enhance and support technical skills, knowledge of processes and the continuous evolution of materials, and which can adapt to a range of application requirements, ensuring high cutting speeds and control over production costs. The **Primus Series** is the range of waterjet cutting machines designed to meet the needs of companies looking for maximum versatility. It enables a wide range of materials to be machined, from stone and metal to glass, plastic, ceramics and composite materials.

A photograph of two men in a workshop setting, overlaid with a red tint. The man in the foreground has a beard and is smiling slightly. The man in the background is out of focus. In the bottom left corner, a portion of a white metal machine is visible, with a red label that says "INTERMAC".

PRIMUS

- ✓ IDEAL FOR CUTTING ANY TYPE OF MATERIAL AND FOR PERFORMING ALL COMPLEX SHAPING OPERATIONS
- ✓ HIGH QUALITY AND PRECISION AND OPTIMUM CUT FINISH
- ✓ EXCELLENT PERFORMANCE AND OPTIMISATION OF CUTTING COSTS
- ✓ CUTTING-EDGE TECHNOLOGY THANKS TO THE PATENTED INTERMAC C-AXIS INFINITE ROTATION SYSTEM
- ✓ SET-UP TIMES REDUCED TO ZERO THANKS TO THE SIMPLICITY OF THE FIXING AND SETTING SYSTEMS

IDEAL FOR CUTTING ANY TYPE OF MATERIAL



Ease of use and the ability to cut all types of materials combined with high quality and precision and optimal cut finishes make the Primus range suitable for a wide range of users.



Primus enables a wide range of ferrous and non-ferrous materials to be processed, including non-metallic alloys, titanium, aluminium, plastics and composites.

The Primus 402 can be configured with either a single or double cutting head.



With special applications for variable Z-axis machining operations, this system allows three-dimensional materials to be processed using dedicated software.

The **Primus 202** can be configured with either a single or double cutting head.



The cutting process makes use of Waterjet technology, which machines materials by means of a high-speed jet of water and abrasive (where necessary), with pressures that can reach 400 MPa.

HIGH QUALITY AND PRECISION AND OPTIMUM CUT FINISH



Primus is the technological solution that looks to the future and is always ready to perform any type of complex shaping operation, including boring directly into the material.

**PERFECT CUT FINISH WITH
NATURAL STONE, CERAMIC
AND SINTERED MATERIALS.**



CUTTING FINISH ON GLASS DESIGNED FOR PROCEEDING TO THE TEMPERING PROCESS WITH NO NEED FOR SECONDARY MACHINING OPERATIONS.



The Primus 322 can be configured with either a single or double cutting head.

IDEAL FOR CUTTING LAMINATED AND FLOAT GLASS, PLYWOOD, ARMoured AND FIREPROOF MATERIALS.

PERFORMANCE AND PRODUCTIVITY



Primus can be configured with one or more independent* cutting heads to meet the customer's production needs.

Work can be done on 3 or 5 axes, which allows for 45 degree cuts or 0 to +/-60° angled cuts to be performed, as well as chamfering or countersinking operations.

Each cutting head is fitted with an independent, automatic abrasive management system to constantly ensure the right amount for the machining operation in hand.



The software automatically adapts the number of cutting heads to suit the panels being created, to guarantee maximum productivity at all times without losing sight of flexibility requirements (one cutting head for pieces that are different from each other, or two for cutting several identical pieces simultaneously).

*not available for the Primus 184.

A SOLUTION FOR EVERY NEED

Maximum scope for customisation in order to respond to market demands for a solution that adapts to materials as they evolve, as well as to a host of very varied application requirements.

PRIMUS 402

The Primus 402 is the ideal solution for machining all materials with a size of 4000x2000 mm.



THE PRIMUS 184 IS THE IDEAL SOLUTION FOR ALL WORKSHOPS WITH LIMITED SPACE.

The Primus 184 is designed as a plug-and-play system that enables production to begin straight away. It stands out for its compact overall dimensions - the electrical cabinet is integrated into the console cabin, while the optional abrasive removal system is incorporated into the structure of the machine itself.



WIDE RANGE OF WORK TABLE CONFIGURATIONS

Support surfaces are available for special materials and applications, to minimise the reverberation of the jet of water on the material being machined and to facilitate the drainage of water and small machining residues.

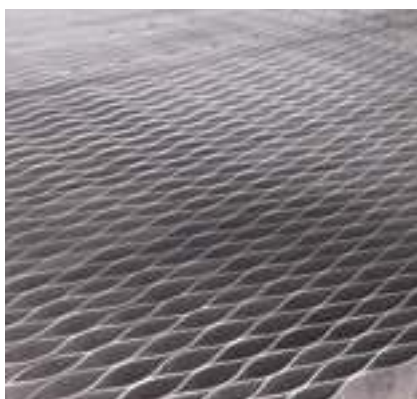

Stainless steel table for pure waterjet applications.



Option of placing more than one template on the work table, in order to increase productivity.



Locking/tooling systems for round or square pipes.

SETTING AND LOCKING THE PANEL IN PLACE IS AS SIMPLE AS POSSIBLE

Once the piece has been positioned on the table and the machining parameters have been entered, the machine is ready to start cutting. Locking the panel being machined in place is extremely simple - or rather, not even necessary - and machine settings times are close to zero.



Aluminium square for panel positioning.



Clamps for locking the panel in place from 4 to 50 mm.



Clamps for locking the panel in place from 1 to 3 mm.

OPTIMISED CUTTING COSTS

Costs are optimised without compromising productivity, thanks to the dynamic control over the flow of abrasive and over the key parameters, to ensure that the machine can maintain maximum productivity and offer accurate control over production costs.

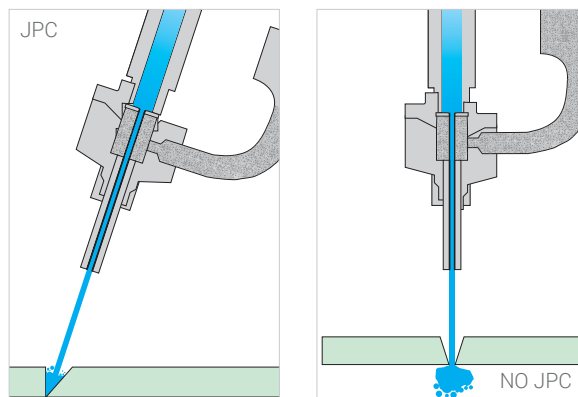

Developed by Intermac, JPC (Jet Performance Control) technology maximises machining efficiency in terms of profile quality and cutting speed.



The thickness tracer system automatically adjusts the optimum distance between the cutting head and the surface of the piece being machined, improving the quality of the cut and guaranteeing the utmost safety during machining operations.

ZERO SET-UP TIMES

Thanks to the automatic centering of the 5-axis head, the time taken to perform this operation can be reduced by approximately 90% following the replacement of cutting head components.



Maximum accessibility in total safety.

The main advantage of this new solution with opening casing is that it enables customers to quickly inspect the head unit and perform maintenance operations, with no need to remove the casing.

Laser pointer for defining the positioning of the sheet on the work table. The laser pointer can be used for manual template learning.

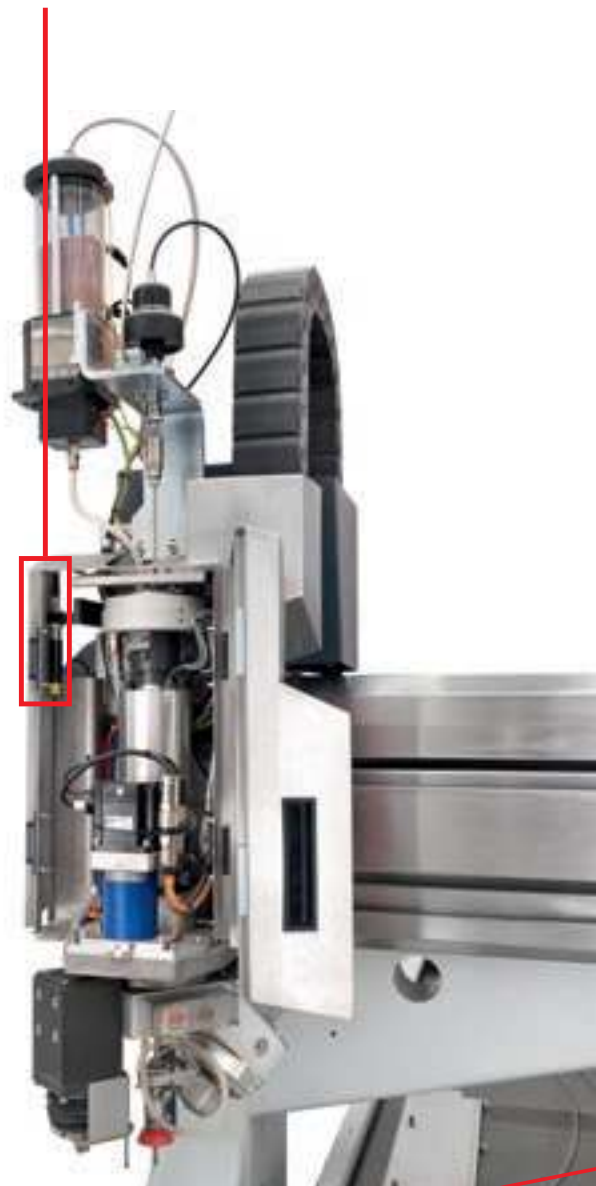

TECH NOLO GY

C-AXIS WITH ENDLESS ROTATION

Maximum programming flexibility thanks to the free movement of the cutting head.

The 5-axis cutting head is equipped with a patented endless rotation C-axis system, which allows sloping cut profiles ($\pm 60^\circ$) to be produced with the best possible quality even when working with complex shapes, with no limitations.

This system eliminates the errors often found in traditional systems resulting from the rotating axis reverse clearance, as well as guaranteeing a constant supply of abrasive material.



EASY TO LOAD AND UNLOAD FOR THE OPERATOR

A compact and ergonomic solution with maximum accessibility on 3 sides, enabling material to be loaded and unloaded with ease.



Option to fit front and rear rollers to facilitate material loading and unloading.

MACHINING CAN ALSO BE PERFORMED IN DOUBLE STATION CONFIGURATION, DIVIDING THE ENTIRE WORKING AREA INTO TWO ZONES.

In one of these two zones, the machine continues to cut, while the operator can safely unload and load pieces in the other area in the meantime.

The barrier that divides the table into two can be easily removed, so that the operator always has the option of using the maximum working area, operating in a single zone when necessary.



MAXIMUM EASE OF USE

The quality of the cut and the main machining parameters (such as the capacity of the abrasive material) are controlled via the software, and can be altered at any time - even while the piece is already being machined. This means the machine operator has full control over production costs.



The hand-held terminal allows the operator to carry out the main machine operations with great ease and safety, as he can move away from the control panel when necessary.



The optional photographic detection system is particularly suitable for open machine operations, where the contours of the natural stone must be followed. Another key advantage lies in the ability to optimise even partially used panels or panels with imperfections, by discarding just the part of the material where the defect is present.



HIGH EFFICIENCY AND ENERGY SAVINGS

Maximum levels of professional performance thanks to the advanced pump technology system.

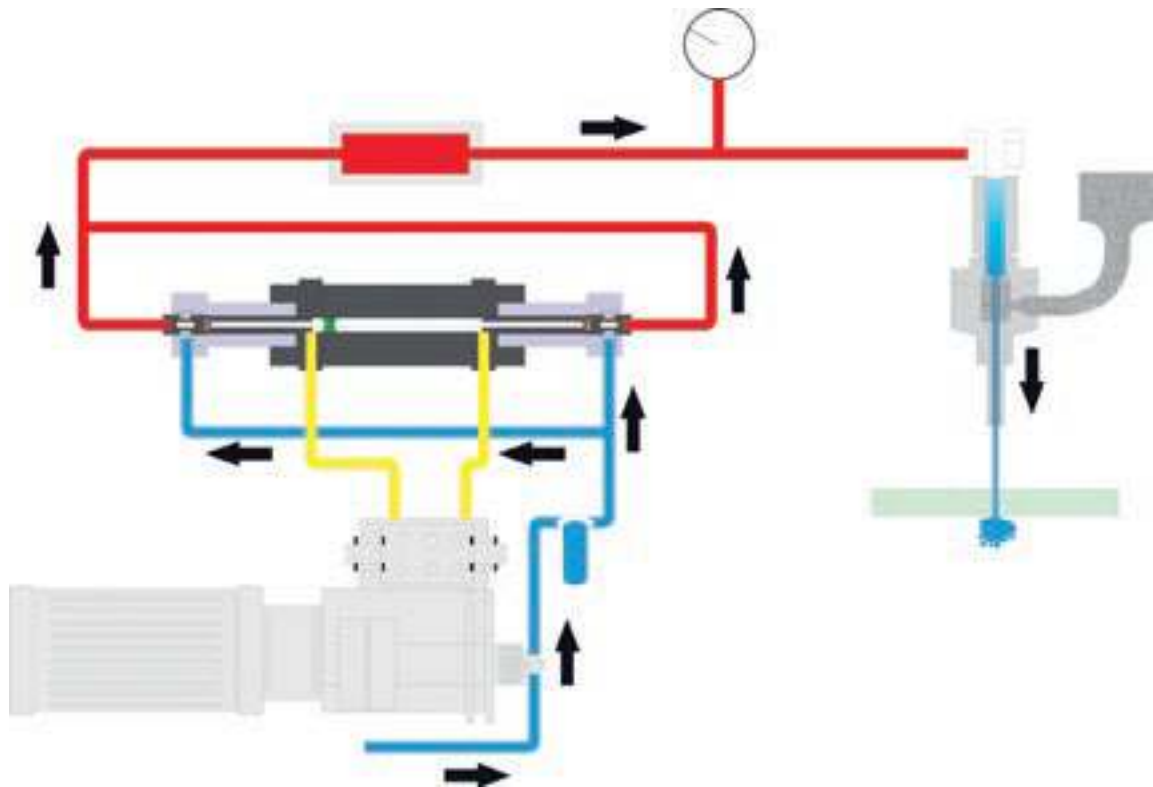

ECOTRON

The excellent quality/price ratio is the main advantage of this pump model. The pressure is generated by an axial piston pump, which is precisely regulated by a standard proportional valve.

A complete range of extra high pressure intensifiers to meet the needs of even the most demanding customer. All the systems are fitted with a high-volume pressure accumulator (2.49 l) to minimise the typical pressure fluctuations and component wear. The proportional valve allows the pressure intensity to be altered to suit the material being machined and the type of cut to be made. Maximum access to all parts subject to wear, to facilitate maintenance and repair operations.



SERVOTRON

The pressure is managed via a frequency-regulated servomotor (BFT patented), which enables energy savings of around 24% more than those offered by conventional pumps. This technology also increases the lifespan of the high pressure components (seals, valves) and helps to reduce wear across the entire high pressure system, from the pump to the cutting head.



HYTRON 40.75

The pump is equipped with two air multipliers, regulated by two axial piston pumps which use an electronic control system in order to guarantee an optimal pressure flow.

Thanks to the high flow rate it delivers, this type of pump is ideal for customers who work with thicker panels and for those who wish to maintain good working speeds, even when operating with multiple cutting heads.



MAXIMUM EFFICIENCY WHEN MANAGING ABRASIVE



The abrasive propulsion system enables the operator to load more abrasive into the first tank without having to stop the machine.

It is composed of two parts - a first tank with a load capacity of around 330 kg of abrasive, and a second pressurised tank.



The automatic removal system for used abrasive features a 1 m³ Big Bag door, with control panel, PLC and management software, so it can be used independently of the machine.

This new solution allows the working hours of the abrasive removal system to be programmed for any time of day, so that the system can be used during the night, for example, taking advantage of any discounted electricity tariffs; the option of performing maintenance operations on the system without having to stop the machine is another key advantage (not available on the Primus 184).

PROTECTION AND SAFETY FOR ALL MACHINING OPERATIONS

Intermac has always paid the utmost attention to the health and safety of its customers. The protection of every operator during the use of the machine is of vital importance, preventing any possible distraction or error that could lead to inconvenience or even accidents.



Photocells
at the sides of the machine.

Full respect for machinery directives and workplace health and safety regulations is an indispensable condition for obtaining any sort of financing.

THE SIMPLEST RESPONSE

WITH OVER 6,500 PACKAGES INSTALLED AND USED BY SATISFIED CUSTOMERS IN 180 COUNTRIES THROUGHOUT THE WORLD, ICAM IS A HIGHLY RELIABLE AND ROBUST SOFTWARE THAT COMBINES TOP PERFORMANCE WITH EXTREMELY EASY USE.

▸ **User-friendly**

A simple, powerful interface for working quickly and easily.

▸ **Time saving**

Positioning of stops and suction cups within the CAD/CAM environment, minimising tooling times even with project modifications.

▸ **Innovative**

A unified interface for the CAD and CAM environments.

▸ **Automated**

The parametric library and Indoor module allow machining operations to be generated quickly and automatically on the basis of the item being created.

▸ **Service quality**

Worldwide Service with a high level of expertise.

DESIGNED TO MEET THE REAL PROGRAMMING NEEDS OF MASTER WORKING CENTRES, WITH THE AIM OF MAKING THE JOB QUICKER AND EASIER. SOLUTIONS BASED ON THE STANDARDS BUT FOCUSED ON THE FUTURE.



TECHNICAL SPECIFICATIONS

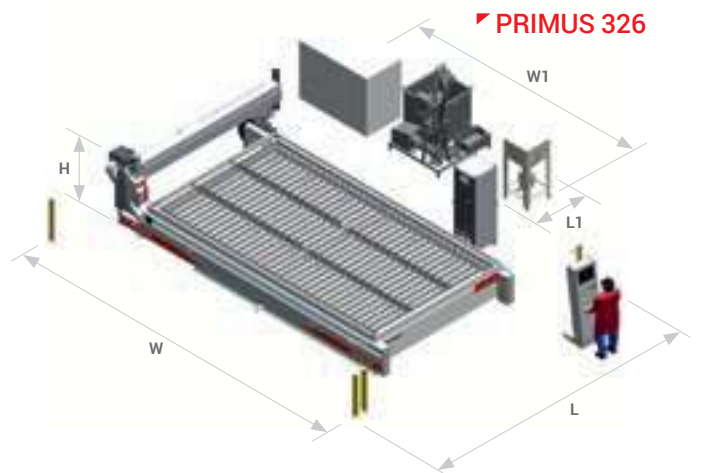
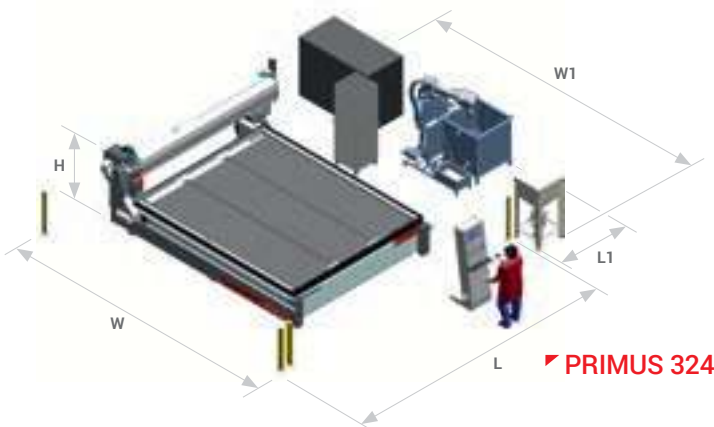
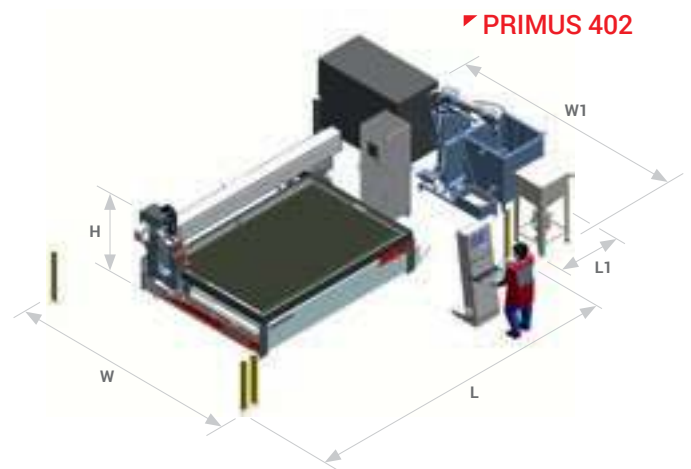
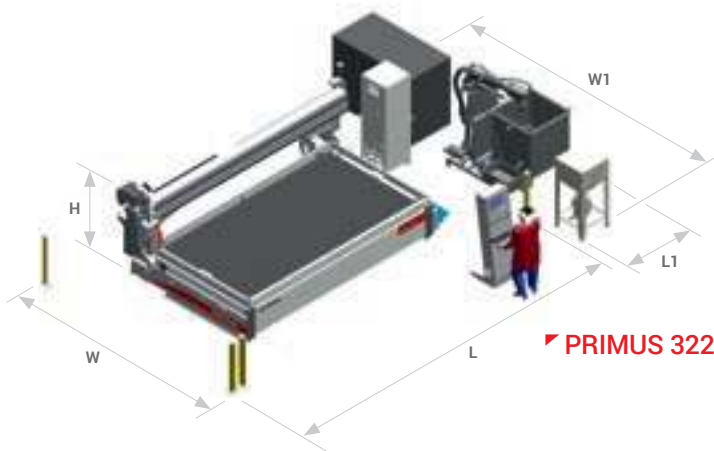
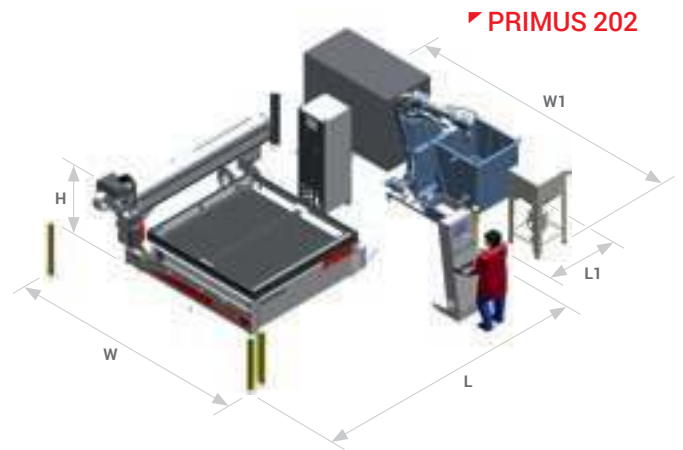
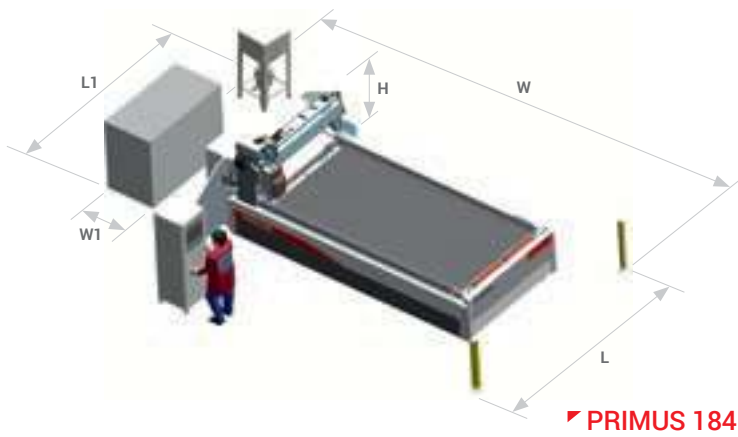

	PRIMUS 184	PRIMUS 202	PRIMUS 322	PRIMUS 402	PRIMUS 324	PRIMUS 326
Working area X-Y (mm)	1860x4000 1700x3800*	2000x2000	3210x2000	4000x2000	3210x4000	3210x6000
Maximum sheet dimensions for loading X-Y (mm)	2010x4300	2080x2250	3300x2250	4100x2250	3300x4300	3300x6300
Z axis stroke	250 (200 with 5-axis head)					
Maximum speed of X-Y axes	45m/min					
Maximum capacity of the piece support table	1000kg/sq.m					
A-axis	+/-60°					
C-axis (opt.)	Endless					
Minimum centre distance between cutting heads (3 axes)	-	280mm				
Minimum centre distance between cutting heads (3 + 5 axes)	-	340mm				
Minimum centre distance between cutting heads (5 axes)	-	500mm				

*with 5-axis cutting head

UHP INTENSIFIER - TECHNICAL DATA

Intensifier power	22 kW	30 kW	37 kW	45 kW	75 kW
Max. pressure	420 Mpa				
Max. water flow rate	2 l / min	3.2 l / min	3.8 l / min	4.1 l / min	7.8 l / min

OVERALL DIMENSIONS		PRIMUS 184	PRIMUS 202	PRIMUS 322	PRIMUS 402	PRIMUS 324	PRIMUS 326
L	mm	3900	5070	6280	7590	6280	6280
L1	mm	3900	1650	1650	1650	1650	1650
W	mm	6490	4940	4940	4940	7130	9210
W1	mm	800	4940	4940	4940	4940	4940
H max (standard)	mm	3000	5000	5000	5000	3000	3000
H max (optional)	mm	-	3000	3000	3000	-	-

The technical specifications and drawings are non-binding. Some photos may show machines equipped with optional features. Biesse Spa reserves the right to carry out modifications without prior notice.

Weighted sound pressure level A (LpA) during machining at the operator's workstation on the vane-pump machine Lpa=79dB(A) Lwa=96dB(A) Weighted sound-pressure level A (LpA) at the operator's workstation and sound power level (Lwa) during machining on the cam-pump machine Lwa=83dB(A) Lwa=100dB(A) Measurement uncertainty K dB(A) 4.

The measurement was carried out in compliance with UNI EN 848-3:2007, UNI EN ISO 3746: 2009 (sound power) and UNI EN ISO 11202: 2009 (sound pressure levels at workstation) during panel machining. The noise levels shown are emission levels and do not necessarily correspond to safe operation levels. Despite the fact that there is a relationship between emission and exposure levels, this may not be used in a reliable manner to establish whether further measures need to be taken. The factors determining the exposure level for the workforce include length of exposure, work environment characteristics, other sources of dust and noise, etc. i.e. the number of other adjoining machines and processes. At any rate, the above information will enable the operator to better evaluate dangers and risks.

SERV ICE & PARTS

Direct, immediate coordination of service requests between Service and Parts. Support for key customers from specific Intermac personnel, in-house and/or at the customer's site.

INTERMAC SERVICE

- ▣ Machine and line installation and start-up.
- ▣ Training centre for Intermac field technicians and subsidiary/dealer personnel; customer training directly at the customer's site.
- ▣ Overhaul, upgrade, repairs and maintenance.
- ▣ Remote diagnostics and troubleshooting.
- ▣ Software upgrade.

85

Intermac field technicians in Italy and worldwide.

20

Intermac technicians working in Teleservice Centre.

35

certified dealer technicians.

50

training courses in a variety of languages every year.



SERVICE TEAM

The Biesse Group promotes, cares and develops direct and constructive relationships with the customers to meet their needs, improve after-sales products and services through two dedicated areas: Intermac Service and Intermac Parts. With its global network and highly specialised team, the company offers on-site and on-line assistance and spare parts for machines and components anywhere in the world, 24/7.

INTERMAC PARTS

- Original Intermac spare parts and spare parts kits customised to suit the machine model.
- Spare part identification support.
- Offices of DHL, UPS and GLS couriers located within the Intermac spare parts warehouse, with multiple daily pick-ups.
- Optimised order dispatch time, thanks to a global distribution network with de-localised, automated warehouses.

95%
of machine downtime orders dispatched within 24 hours.

95%
of orders dispatched on time.

30
spare parts staff in Italy and worldwide.

150
orders processed every day.

MADE WITH INTERMAC

DIGITAL CHISELS: CHALLENGES IN THE INTERACTION BETWEEN STONE AND 4.0 TECHNOLOGY

At the "Italian Stone Theatre" event that took place during the 2017 edition of Marmomac, Intermac technologies demonstrated their potential in stone machining operations, highlighting the productive and technical ability of the furnishing and design companies involved: Seguso Gianni and Vicentina Marmi. As the designer Raffaello Galotto explained, "The "Rezzonico" lamp is produced using a natural veined marble - a choice that highlights the value of the raw material, lending this serial format a unique quality that it wouldn't otherwise

have. Each single lamp can be considered a unique item because its natural pattern is unrepeatable. From a technical perspective, the 5-axis waterjet machining of the Primus was brought to new levels, considerably limiting waste." The work was produced in collaboration with Generelli Marmi. «The use of the waterjet technology of Intermac's Primus range emphasised the amazing possibilities to transform stone materials into artefacts that are rather complex in both the technical and formal sense. The latest systems used on these ma-

chines guarantee accuracy, working speed and reduced waste; these factors are crucial for the large-scale production of practical objects with complex shapes, and for reaching performance levels similar to those seen with other, lighter materials."

This was the opinion of Matteo Generelli, company owner, after the prototype had been created.

Italian Stone Theatre, Italy

Spotlight on Intermac technology at the
ITALIAN STONE THEATRE.





WATERJET IN THE TESTING LABORATORY

Tenaris is a specialised company that offers advanced technological products and worldwide integrated supply chain management services to the largest companies in the oil and gas sector in the world, as well as to industrial and engineering groups. With an annual production capacity of 950,000 tonnes of finished product, over 2,300 employees, 5 production facilities, and an independently-operated 120 Mw power station that has enabled the facility in Dalmine to be energetically autonomous since 2009, Tenaris Dalmine is Italy's leading domestic manufacturer of seamless steel pipes for the energy, automotive, and mechanical industries. This rich production environment also

includes the activities of the testing laboratory. This facility is part of the Quality Department, and is responsible for carrying out all destructive and non-destructive tests on the pipes, both mechanical and chemical. The waterjet machines are all installed in the test preparation area, and were introduced when the company changed its strategy to focus on the manufacture of thicker pipes.

Today, with these two waterjet systems by Intermac, we are not only capable of processing pipe sections of up to 33 mm thick in a much more favourable manner with respect to traditional machine tools, but we can even boast the exclusive capability of processing sections of

more than 66 mm thick. In addition, we can also cut tempered materials."

"Having incorporated the Primus 202 into our laboratory three years ago, I must say that we are extremely satisfied with our investment: it has provided significant advantages, both in terms of production and economy. Moreover, Intermac's role in the pre-sale phase was crucial to obtaining the best results, both mechanically and with regard to software, as we were able to configure the machines to best suit our needs."

Tenaris, Italy

INDUSTRY 4.0 READY

Industry 4.0 is the latest industry frontier, based on digital technologies and machines that speak to the companies. The products can be interconnected with the production processes via smart networks.



INTERMAC
INDUSTRY 4.0 READY

Intermac's commitment is to transform our customers' factories with real-time technology, ready to guarantee digital manufacturing opportunities, with smart machines and software packages becoming vital tools that facilitate the daily tasks of people all over the world processing glass, stone, metal and more. Our philosophy is a practical one: to supply entrepreneurs with solid data that can help them to lower their costs, optimise their processes and improve their results.

AND THAT MEANS BEING 4.0 READY.



The machine can be configured either in line or as a work cell.



LIVE THE EXPERIENCE

BIESSEGROUP.COM



Interconnected technologies and advanced services that maximise efficiency and productivity, generating new skills to serve better our customer.

LIVE THE BIESSE GROUP EXPERIENCE AT OUR CAMPUSES ACROSS THE WORLD.



BIESSEGROUP

